

Contaminants in wastewater often cause the water to appear turbid or colored. These impurities include suspended and colloidal materials and soluble substances. Because the density of many of these particles is only slightly greater than water, agglomeration or aggregation of particles into a larger floc is necessary in order for them to be removed by sedimentation and filtration. The clarified water then can be either discharged or reused and the settled floc can be collected, dewatered and disposed of as solid waste.

Flocculant and coagulant separation technology play an important part in treating almost every kind of industrial waste stream. Just like all other major divisions of wastewater treatment technology, they have their advantages and limitations. The key is to very clearly determine the best technology for the given situation.

General Definitions

The following is a list of definitions associated with floc technologies:

Flocculant

Long chained polymers of tremendous molecular weight are gently mixed to increase contact through collisions. The result is a faster settling action within a design specific vessel. Typically adequate mixing and settling periods must be provided in order for the coagulation, flocculation, and sedimentation to take place.

Coagulation

The process that causes a reduction of repulsion force between particles or colloids (Zeta Potential) that is present of the charges on the particles. A chemical that when added to water, suspended solids mixture negates the electrical charge (Zeta Potential) in the water, which repels particles and keeps them in suspension. When the coagulant is introduced, the zeta potential in the water is altered thus allowing the individual contaminant particle to agglomerate. Coagulants can be a liquid or a solid and can be added in batch or continuous type reactors.

Encapsulants

Sometimes the material that is flocced out of water contains contaminants that are toxic. In that situation an additional material may be added to the process, called an encapsulant. The purpose of the encapsulant is to bind and surround the toxic substances in the flocced material in a matrix. In addition, the encapsulants add the necessary mass to the coagulated particles enabling them to settle quicker. Encapsulants that are designed to be non-leachable will not allow the contaminant to re-dissolve once it is captured. RGF's EC-2000 and QF series flocs incorporate these encapsulants allowing the settled sludge cakes to pass rigorous leachability tests.

Leachability

The relative measure of how much of a given solid contaminant will dissolve when put under conducive conditions. Heavy metals have certain leachability limits for which a solid must pass to ensure the metals won't leach out of the solid at some point in the future.

Precipitation

All metals, when introduced to water, will dissolve to a certain extent and form ions. In the case of heavy metals, these ions are very toxic. One way to remove them from water is to cause them to turn back into a solid by adjusting the pH of the water. Two things then occur, they become less toxic, and most importantly they are now in a particle form, which can be filtered out by flocculation or ultrafiltration. A typical flocculation system designed to remove heavy metals from water would have a precipitation step subsequent to the injection of the flocculant.

Zeta Potential

The small electrical imbalance created in water by the interaction of water molecules and the small particles and colloids suspended in water. The usually negative charge keeps the particles apart and prevents them from settling. When a coagulant is added to the water, the zeta potential is reduced to zero, allowing the suspended particles to coagulate.

Specific Gravity

The ratio of the density of a liquid relative to that of pure water. Pure water has a density of 1.0g/ml and therefore, by definition, a specific gravity of 1.00. Substances heavier than pure water have specific gravities of greater than one and conversely, substances lighter than water have specific gravities less than one. For example, sea water has approximately 32,000 ppm Total Dissolved Solids, thus is more dense than pure water. Its density is 1.032 divided by 1.0000 or 1.032. On the other hand, oil is lighter than water and has a density of .8g/ml.

Adsorption

The process that occurs when one substance is attracted and adheres to the surface of another. An example of adsorption is when oil particles are drawn out of water by polypropylene fibers and affix to the surface of the fiber. The word "adhere" is a good way to remember the mechanism of adsorption.

TCLP

Solids must pass a series of leachability tests in order for them to be disposed of as nonhazardous waste. The Toxic Chemical Leachability Profile Tests are designed to provide a standardized means of testing the leachability characteristics of solids. They look for common heavy metals and other organic toxins, which are classified as hazardous by regulators.

Bentonite and other Organic Clays

These are the coagulation and encapsulating agents normally included in dry flocculants to aid in the floccing and settling process. In addition to creating the coagulant effect in the wastewater, they adsorb many contaminants and bind them to the floc matrix. In addition, the floc particles are weighted by the clay particles, which allows them to settle much more quickly.

Sludge Cake

The solid mass resulting from the addition of the floc to the wastewater. Contained in the cake are all the contaminants that were drawn out of the water as it was clarified.

Heavy Metals

Heavy metals are the most serious parameter of inorganic material in wastewater because of their toxic effects on life forms. They are most toxic when in their dissolved state. Some common heavy metals are Zinc, Chromium, Nickel, Lead, Mercury, and Cadmium.

Colloid

A homogeneous mixture of compounds in water which remain suspended and contribute to the turbidity and color. They are not individually visible to the human eye. Colloids may also contain toxic substances in need of removal. Coagulation/Flocculation is one of the best technologies for removing colloidal suspended solids from water.

Filtration Aids

Coagulants can be added to a waste stream to increase the filtration efficiency of standard filtration media by causing colloidal suspensions to agglomerate. These larger agglomerated particles are then big enough to be caught in the applicable filter media.



The Flocculation Process

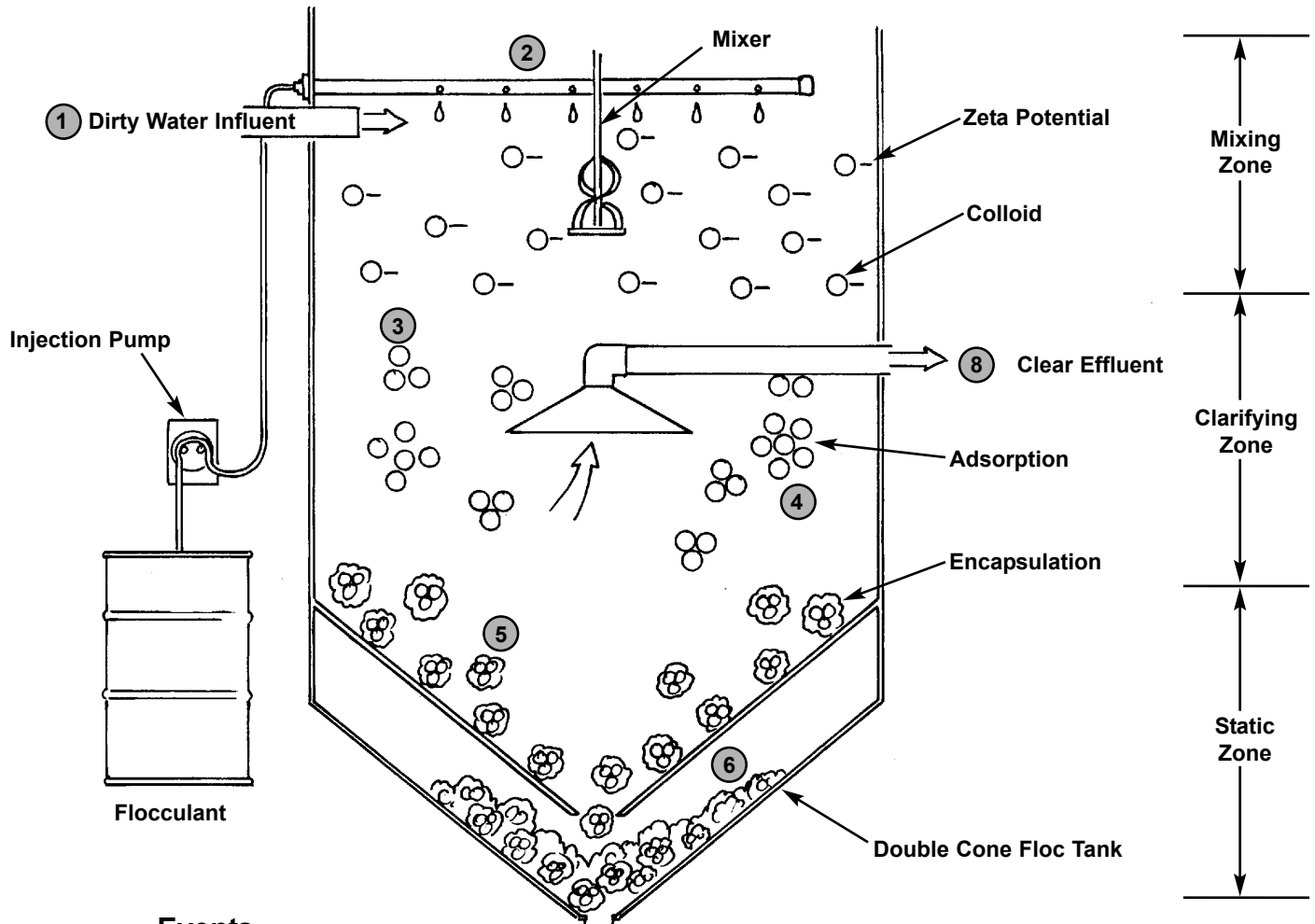

Events

- ① Turbid, cloudy water enters the double cone floc tank.
- ② Flocculant is added and mixed into the waste stream.
- ③ Coagulation of colloids starts to occur.
- ④ The particles then adsorb together.
- ⑤ And become encapsulated in the floc.
- ⑥ Which then settle to the bottom to a static zone.
- ⑦ The settled material is filtered out of the water via the filter paper and collected in a sludge cake.
- ⑧ The clear water is then drained off.

RGF ESP Floc Series Wastewater Encapsulation Treatment Systems

RGF's line of advanced encapsulation treatment systems are fully automatic and capable of treating waste streams contaminated with **emulsified oils, solids, heavy metals, ink and paint emulsions, and floor scrubber wastewater**. The treated water will usually meet sewer discharge requirements or may be reused for cleaning. The resulting dried sludge from the treatment process normally will pass the TCLP test, which will allow its disposal at a nonhazardous landfill. RGF offers a complete line of flocculants modeled to handle any waste stream. Call for details.

RGF ESP-250

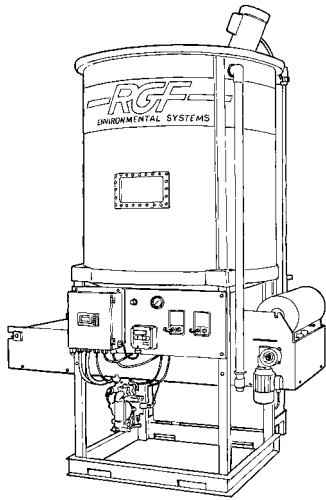

The ESP-250 will process up to 500 gallons per hour. The systems standard equipment list includes a fully automatic PLC controller, observation window, non-intrusive level sensors, visual alarms, and self cleaning reactor. The ESP-250 was designed to be compact and all wetted parts are non-ferrous for long equipment life. The exclusive optional RGF Clear Check System can be installed to monitor the final product for clarity to prevent incomplete batches from discharging and will alert operators if the waste stream was not correctly processed.

- *Treatment Capacity:* 250 gallons per batch
- *Dimensions:* 54" W x 72" L x 102" H
- *Controls:* PLC controller automated
- *Electrical:* 220 Volt, single phase, 20 amps
- *Add't Requirements:* Compressed Air - 100 psi @ 20 scfm

Item #	Description	Treatment Capacity	Ship Wt.
ESP-250-Q	ESP-250 Batch Treatment System	250 gallon Batch Treatment	728 lbs.

RGF ESP-100

The ESP-100 series batch treatment system was designed for versatility and accessibility. This series contains the same standard features as the ESP-250. The ESP-100 will process up to 200 gallons per hour. Also available is an Optional Post Treatment System intended for applications that require process water disinfection prior to discharge or for re-use of the treated water. The Optional Post Treatment System contains a recirculation pump, 25 micron polishing filter and RGF's exclusive CO3P oxidation / disinfection system. The RGF Clear Check System can also be optionally installed on this series.

- *Treatment Capacity:* 100 gallons per batch
- *Dimensions:* 80" W x 72" L x 60" H
- *Controls:* PLC controller automated
- *Electrical:* 220 Volt, single phase, 20 amps
- *Add't Requirements:* compressed air - 100 psi @ 20 scfm

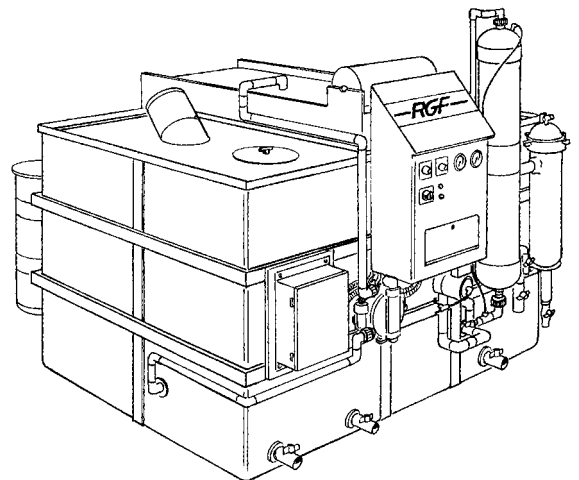

Item #	Description	Treatment Capacity	Ship Wt.
ESP-100-Q	ESP-100 Batch Treatment System	100 gallon Batch Treatment	1127 lbs.

Larger and Custom Floc Treatment Systems Available

CALL RGF Toll Free 1-800-842-7771
International & FL Call 1-561-848-1826

RGF ESP Floc Series Optional Components

RGF Clear Check System

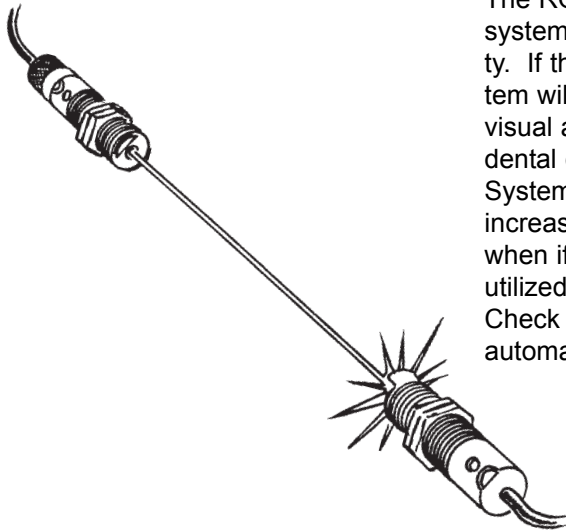

The RGF Clear Check System is the first of its kind for floc systems. The system utilizes advanced Laser Technology to monitor the floc process quality. If the resulting product water is not at the pre-determined quality, the system will automatically shut the process down and alert the operators with a visual alarm. The Clear Check System prevents untreated water from accidental discharge. As an additional option, the RGF Clear Check Plus System has the added feature of re-processing the batch to correct for increases in the solids loading of the waste stream. This is a critical option when if drastic changes in daily water quality are expected or the system is utilized to treat several different waste streams. The Clear Check and Clear Check Plus Systems are installed directly in the processing tank for fully automatic operation.

- *Sensor:* Dual point laser beam
- *Connection:* (2) 3/4" FPT threaded probe fittings
- *Output:* low voltage switch signal
- *Electrical:* 12/24 VDC, 5 amps

Item #	Description	System Applicable	Ship Wt.
OI-056	RGF Clear Check System	RGF ESP Series	Factory Installed
OI-057	RGF Clear Check Plus System	RGF ESP Series	Factory Installed

Pre-Tanks & Storage Tanks

Pretreatment-Tanks and Storage may be required for certain installations. We offer these ready to install tanks in various configurations for the entire ESP series. Pre-Tanks are utilized in front of the ESP as a surge balancing tank or collection tank for the waste stream to be processed. This tank is pre-assembled with a submersible pump and all associated level controls and pipe fittings. Installation is easier and quicker when this tank is purchased.

The Storage Tank is utilized for applications where the water is to be re-used or the water needs further treatment such as disinfection prior to discharge. This tank is pre-assembled with all associated level controls and pipe fittings. Optional fittings can be installed to accommodate a disinfection system such as RGF CO³P system.

- *Construction:* UV protected polyethylene
- *Manway:* 16" diameter vented
- *Level Controls:* float switch activated, visual sight glass
- *Options:* RGF CO³P System Disinfection System
RGF Corona Discharge Generators

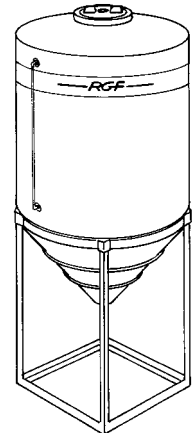
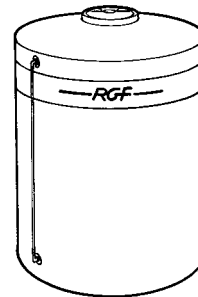

Item #	Description	Tank Capacity	Dimensions	Ship Wt.
OP-099	300 gallon Pre-Tank	300 gallons	48" dia. x 48"H	50 lbs.
OP-100	500 gallon Pre-Tank	500 gallons	48" dia. x 72"H	100 lbs.
SA-127	400 gallon cone bottom Pre-Tank	400 gallons	48" dia. x 153"H	521 lbs.
OP-101	300 gallon Storage Tank	300 gallons	48" dia. x 48"H	50 lbs.
OP-102	500 gallon Storage Tank	500 gallons	48" dia. x 72"H	100 lbs.

Model FS-30 Portable Floc System

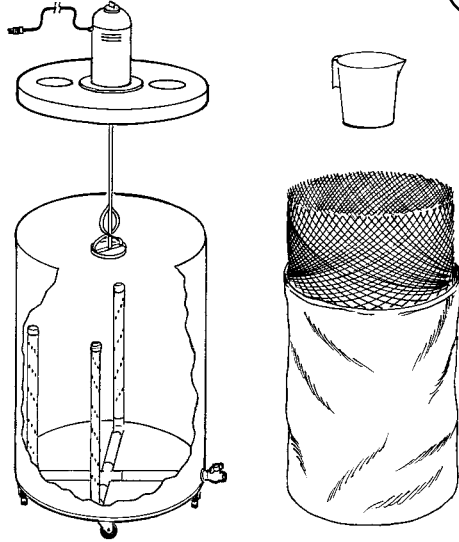

Designed to adequately treat for reuse or disposal, diverse waste streams ranging from floor scrubber water to parts washer wastewater where environmental regulations limit discharges without special pretreatment. The RGF model FS-30 reduces prohibited contaminants from the waste stream and encapsulates them in a nonleachable solid waste for easy disposal.

- **Dimensions:** 53"H x 21"W
- **Electrical:** 115 VAC, 60 Hz, 10 Amps
- **Discharge Outlet:** 3/4" Diameter Sch 40 PVC

Item #	Description	Treatment Capacity	Ship Wt.
FS-30-V	FS-30 Portable Floc System	30 gallons / batch	41 lbs.

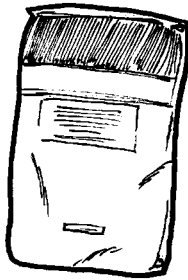

Floccing Agents

RGF's Floccing Agents QF-10 and QF-20 are designed to accommodate most applications. We also have several custom blends that target specific waste streams. Call RGF to help in the decision as to what blend will be right for your application. Blends are also available in granular form to decrease the dust level.

Item #	Description	Floc Type	System	Quantity	Ship Wt.
QF-10P	Quick Floc Flocculant (powder)	Dry Floc	RGF ESP Series	per lb.	per lb.
QF-10G	Quick Floc Flocculant (granular)	Dry Floc	RGF ESP Series	per lb.	per lb.
QF-20P	Quick Floc Flocculant (powder)	Dry Floc	RGF ESP Series	per lb.	per lb.
QF-20G	Quick Floc Flocculant (granular)	Dry Floc	RGF ESP Series	per lb.	per lb.
CE-020	RGF Clarifying Agent 6472	Liquid Floc	Double Cone Tank	5 gal. pail	45 lbs.
CE-021	Emulsion Splitting Agent	Liquid Floc	Double Cone Tank	5 gal. pail	45 lbs.

j Call for Volume Discounts j

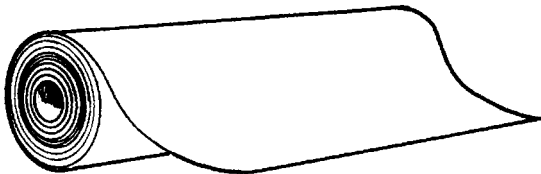

Filter Paper

RGF's Filter Paper is utilized on the dewatering filters for the RGF ESP Series of systems.

Item #	Description	System	Quantity	Ship Wt.
FL-074	24" Wide Filter Paper	RGF ESP-100 and 50	250 Yards	10 lbs. per roll
FL-119	28.75" Wide Filter Paper	RGF ESP-250	250 Yards	10 lbs. per roll

