

BIOLOGICAL TREATMENT

There are two basic biological treatment processes: aerobic (with oxygen) and anaerobic (without oxygen).

Aerobic Treatment is the process by which microorganisms use the waste's organic component with oxygen, which produces cell growth and end products of carbon dioxide and water. The most popular is the activated sludge process which is commonly used for domestic and industrial wastewater. This process provides a high quality effluent and is capable of reducing B.O.D. by 95%. The bacterial process oxidizes the soluble and suspended organics to carbon dioxide and water in the presence of oxygen. The organic material is converted into new cells or used to support growth of existing cells. The excess of cells is sludge.

Anaerobic Treatment is the process where microorganisms convert organic compounds to methane, carbon dioxide, cellular materials, and other organic compounds. The anaerobic process converts organic wastes to methane and carbon dioxide in the absence of air. Anaerobic treatment has the ability to perform the following decompositions:

- **Hydrolysis** - A breakdown of suspended organic solids into soluble organic compounds.
- **Acetogenesis** - A conversion of soluble organics to volatile fatty acids.
- **Methanogenesis** - A conversion of the volatile fatty acids into methane.

It is important to remember the following when utilizing a bio system:

- **It can take up to three (3) weeks to develop a bacteria colony within the bio-digesters.**
- **Bio systems need a high B.O.D. load to live on (at least 100 ppm).**
- **Bacteria are pH and temperature sensitive.**
- **Continuous circulation is required.**
- **An oxidizing agent entering the system can kill the bacteria, thereby requiring a new start-up.**

There are five (5) processes required in a complete industrial bio system:

- **Pre-Screening** - to remove solids from the waste stream.
- **Anaerobic Treatment** - or a breakdown to a septic condition. Partial breakdown to methane, carbon dioxide, cellular material and organic compounds.
- **Aerobic Treatment** - A reduction of 95% B.O.D. A complete breakdown to carbon dioxide and water.
- **Clarifier** - Removal of active bacteria and other suspended solids.
- **Effluent Disinfection** - Oxidation of pathogenic bacteria and viruses.

TYPICAL INDUSTRIAL BIO SYSTEM

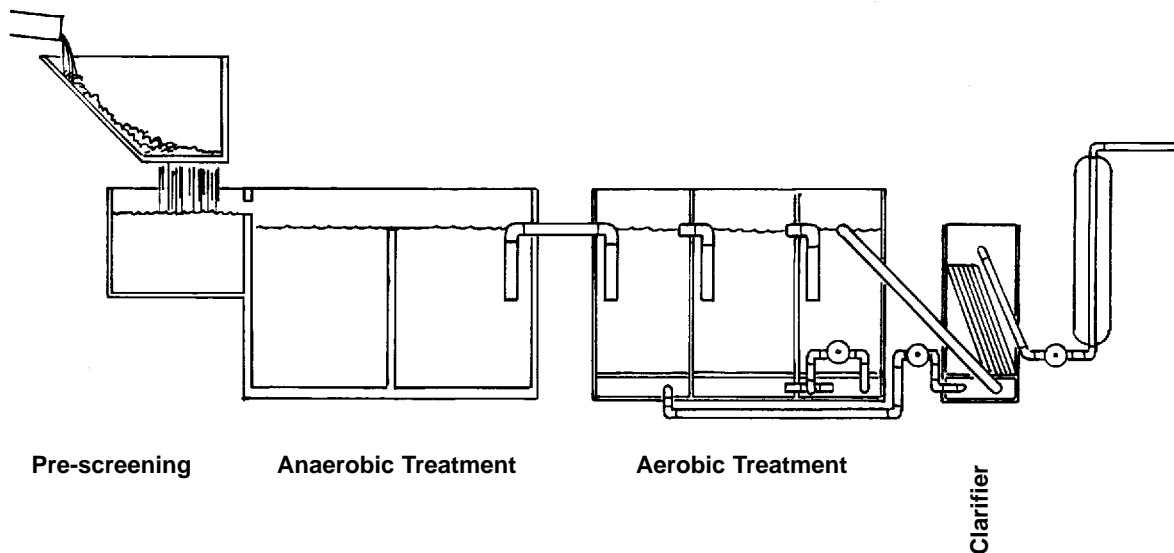

Modular RGF BioSorb Advanced Wastewater Treatment System

The RGF Modular Biosorb System was designed to accommodate a variety of wastewater applications and requirements with high B.O.D. and C.O.D. levels. The system is intended for the treatment of sewage or biodegradable industrial wastewaters from applications such as: Housing Developments, Work Camps, Resorts, Food Processing Plants, Marinas, and Small Industrial applications. The concept is to combine a series of the Modular Biosorb System components together to accommodate your particular wastewater treatment needs for either irrigation, re-use or pre-treatment for discharge.

The main component of the system is the three-compartment aerobic **Biosorb Digester Module** which is designed to rapidly break-down organic substances through the use of bacteria and enzymes. The natural biological process is enhanced through the use of an air injection pump and RGF's unique BioSorb media. The **Clarifier Modules** separates the bacteria and returns it to the first compartment for revitalization. **Pre-screening/Lift Station Modules** or **Grease Trap Modules** can be utilized for the collection of water and removal of heavy solids, greases, and fats. Post-treatment disinfection modules include the **Chlorine Disinfection Module** and the **Catalytic Oxidation Disinfection Module**. In addition, RGF can custom design a **Re-Use Module** for use in an irrigation system or industrial or food processing applications.

TYPICAL EQUIPMENT LAYOUT

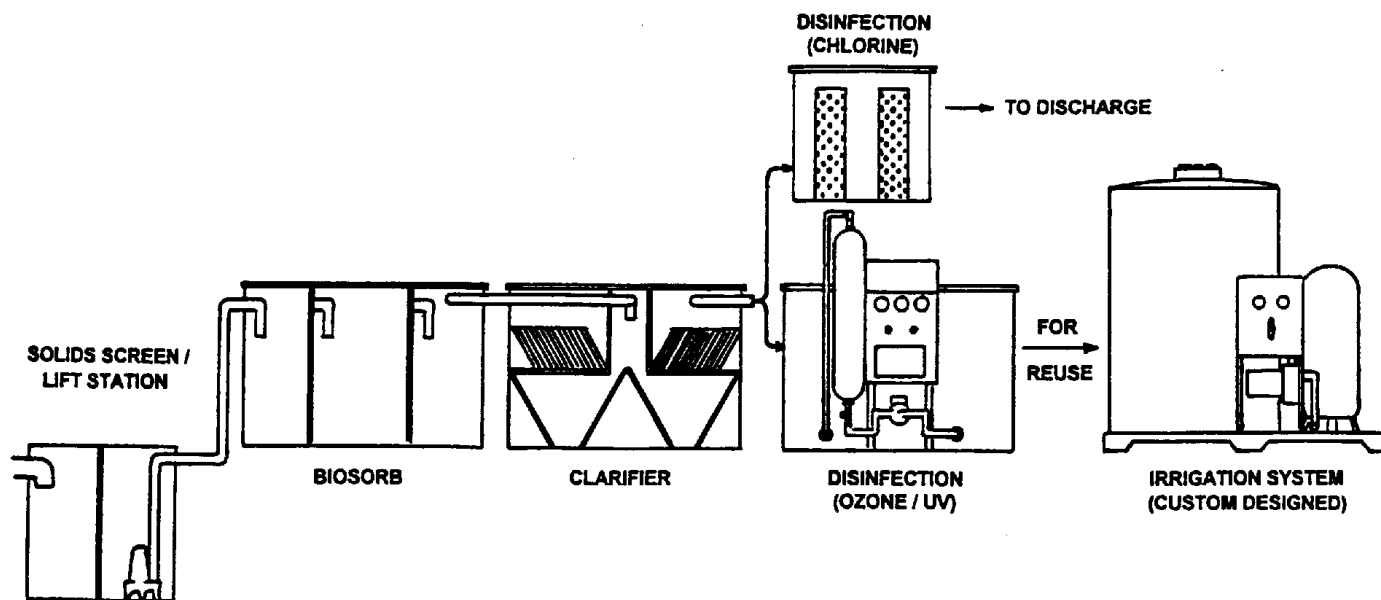

MODULAR DESIGN DATA

Biosorb Model	Number Persons	Volume (Gals/Day)	Flow Rate (Gals/Hr)	B.O.D. (Lbs/Day)	Biosorb Modules	Clarifier Module	Air Supply (cfm@2 psi)	Sludge Recycle (Gals/Hr)
M1	22	1,000	250	2.5	1	AP	25	250
M2	44	2,000	500	5.0	2	B	50	500
M3	66	3,000	750	7.5	3	B	75	750
M4	88	4,000	500	10.0	4	B	100	500
M5	110	5,000	625	12.5	5	B	125	625
M6	132	6,000	750	15.0	6	B	150	750

Call RGF with your application needs and a system integrator will help you design in the appropriate modular system to meet your needs.



Modular RGF BioSorb Advanced Wastewater Treatment System

RGF Biosorb Digester Module

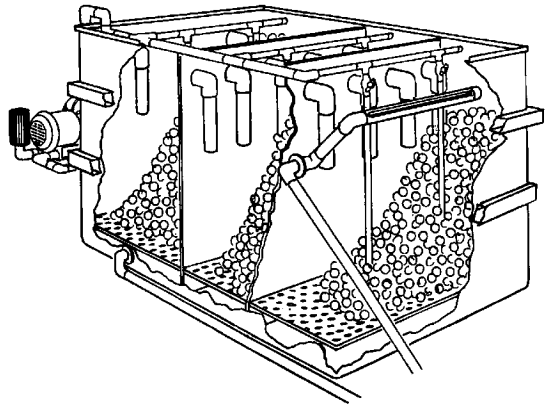

The Biosorb Digester Module is the main component of the modular design. Several Biosorb modules can be coupled together to accomplish higher flow rates. The Biosorb Module utilizes the following proven technologies for aerobic BOD/COD removal: fixed film biomedica, activated sludge, and regenerative aeration.

- *Flow Rate:* 1,000 g.p.d.
- *Dimensions:* 52"W x 60"L x 46"H
- *Electrical:* Regenerative Air Blower - 110/220 VAC, 50/60 Hz
- *Operating Temperature:* 33 - 100°F
- *pH Range:* 6.5 - 9.5
- *BOD/COD Reduction:* 95%
- *Biosorb Media:* 40 ft³ Polypropylene Media
- *Air Feed Blower:* 1 h.p. regenerative rotary vane blower
- *Materials:* polypropylene biomedica, polyethylene tank, PVC piping, epoxy coated steel frame (s.s. optional)
- *Options:* poly vinyl cover

Item #	Description	Module Type	Flow Rate	Ship Wt.
BIO-1	RGF BioSorb Module	Aerobic Biodigester	1,000 g.p.d.	1,050 lbs.

RGF Screen / Lift Module

A durable, lightweight polyethylene vessel with large solids prescreen and macerator pump. This module serves as a convenient central collection sump station

- *Flow Rate:* 10 g.p.m.
- *Dimensions:* 35"W x 35"L x 40"H
- *Electrical:* Macerator Pump - 110/220 VAC, 50/60 Hz
- *Operating Temperature:* 33 - 100°F
- *pH Range:* 6.5 - 9.5
- *Materials:* polyethylene tank, polypropylene screen
- *Options:* poly vinyl or steel cover

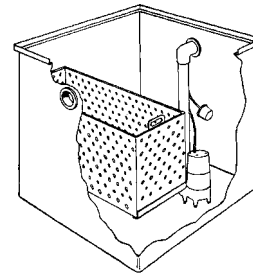

Item #	Description	Module Type	Flow Rate	Ship Wt.
SC-LS	RGF Screen/Lift Station Module	Lift Station / Macerator	600 gals/hr	285 lbs.

RGF Grease Trap Module

Designed to handle up to 20 gallons per minute, the Grease Trap Module is intended to collect heavy oils, grease and fats prior to entry into the Biosorb or lift station modules.

- *Flow Rate:* 20 g.p.m. maximum
- *Dimensions:* 35"W x 48"L x 40"H
- *Operating Temperature:* 33 - 100°F
- *pH Range:* 6.5 - 9.5
- *Materials:* polyethylene tank, polypropylene screen, PVC Piping
- *Options:* poly vinyl or steel cover
enzymatic grease digestion system

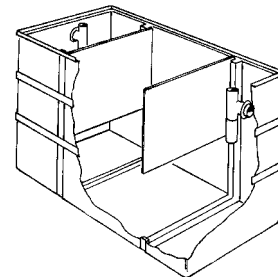

Item #	Description	Filter Type	Flow Rate	Ship Wt.
GR-20	RGF Grease Trap Module	Oils, Grease, Fats	600 gals/hr	450 lbs. lbs.

Modular RGF BioSorb Advanced Wastewater Treatment System

RGF Clarifying Modules

RGF Clarifying AP Module

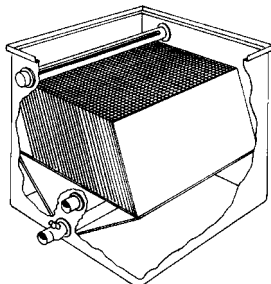

The Clarifying Modules are designed to settle out the biomass from the treatment process, collect and reactivate it back into the Biosorb Modules. Clarifier Module AP is designed for up to 1,000 g.p.d and Clarifier Module B is design for up to 7,500 g.p.d.

- **Flow Rate:** Clarifier AP - 1,000 g.p.d.
Clarifier B - 7,500 g.p.d.
- **Dimensions:** Clarifier AP - 35"W x 35"L x 40"H
Clarifier B - 53"W x 73"L x 46"H
- **Materials:** polyethylene tank, Polypro incline plates, PVC piping, epoxy coated steel frame (s.s. optional)
- **Options:** poly vinyl or steel cover

RGF Clarifying B Module

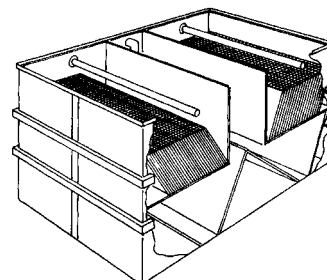

Item #	Description	Module Type	Flow Rate	Ship Wt.
CL-AP	RGF Clarifier AP Module	Biomass Settling Tank	1,000 g.p.d.	235 lbs.
CL-B	RGF Clarifier B Module	Biomass Settling Tank	7,500 g.p.d.	480 lbs.

RGF Disinfection Modules

RGF Chlorine Disinfection Module

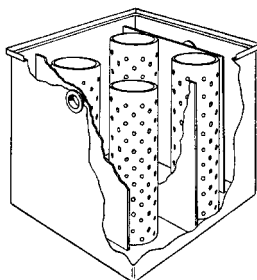

The Disinfection Modules are designed to disinfect the treated water to meet discharge standards or prepare it for re-use. The Chlorine Module is a time proven tablet style chlorine system and the Catalytic Oxidation Module is an advanced oxidation ozone and ultraviolet light disinfection system for complete disinfection.

- **Flow Rate:** Chlorine Module - 2,000 g.p.d.
Catalytic Module - 6,000 g.p.d.
- **Dimensions:** Chlorine - 35"W x 35"L x 40"H
Catalytic - 53"W x 73"L x 46"H
- **Materials:** polyethylene tank, PVC piping, epoxy coated steel frame (s.s. optional)
- **Options:** poly vinyl cover

RGF Catalytic Oxidation Disinfection Module

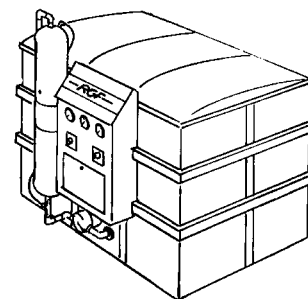

Item #	Description	Module Type	Flow Rate	Ship Wt.
CH-DI	RGF Chlorine Module	Chlorine Disinfection	2,000 gals/day	250 lbs.
CATOX-DI	RGF Catalytic Oxidation Module	Advanced Oxidation Disinfection	6,000 gals/day	525 lbs.

RGF Irrigation/Re-Use Module

The Irrigation or Re-Use Modules are custom designed to suit your particular application. These modules can include storage capacity, re-pressurization pumps, filtration, and additional ozone or catalytic oxidation. Contact RGF and a system integrator will help you design a custom system to suit your application.

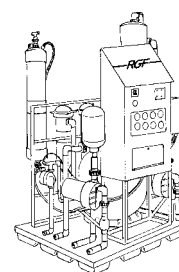
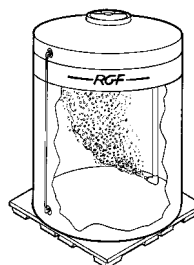

Description	Module Type	Flow Rate	Ship Wt.
RGF Custom Design Irrigation/Re-Use Module	Irrigation or Re-Use	Custom	CALL



BIOLOGICAL TREATMENT SYSTEMS

RGF BioSorb Advanced Residential Sewage Treatment System

A packaged aerobic digester with self-cleaning media, aeration and ozonation that follows a standard septic tank. Processed domestic wastewater can be used for subsurface irrigation.

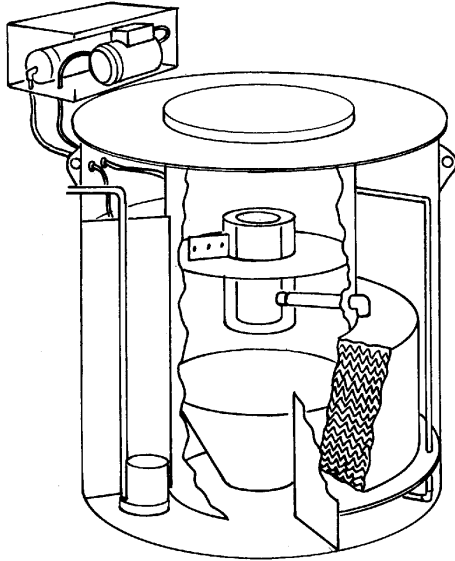

- *Max. Flow Rate:* 500 g.p.d.
- *Dimension:* 144" Dia. x 84"H
- *Electrical:* 120 VAC, 30 Amps, 50 / 60 Hz
- *Operating Temperature Range:* 30 - 90° F
- *pH Range:* 4 - 9
- *BioSorb Media:* 40 cubic feet
- *B.O.D. / C.O.D. Reduction:* Up to 95%
- *Material:* Polypropylene Bio media, Polyethylene Tank, PVC Piping

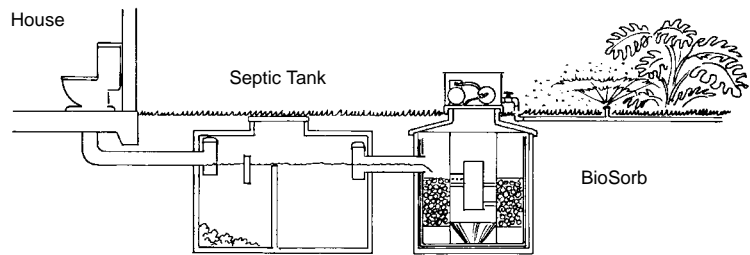

Item #	Description	Filter Type	Flow Rate	Ship Wt.
BIO-2	RGF BioSorb Sewage Treatment System	BioSorb Media	500 g.p.d.	1,450 lbs.

RGF Enzymatic Bio-Disks Natural Bacteria Biological Disks

The RGF Enzymatic Bio-Disks are hard "Hockey-puck" style disks that slowly dissolve to release a continuous flow of safe bacteria that literally digest waste water contaminant's such as oils and greases, converting them to carbon dioxide and water.

GT Bio-Disks by RGF

The GT Bio-disks are safe, natural bacteria that reduces grease, fats, oils, proteins, lipids and detergents in grease traps by a factor of four. If you are presently pumping your grease trap once per month, two to four Bio-disks per month can reduce pumping to four months and longer with RGF's Bio-disk Aeration System. These Bio-disks eliminate the need for liquid injection pumps and the high cost of liquid bacteria.

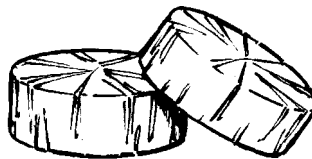

OWS Bio-Disks by RGF

The OWS Bio-disks contain a live synergistic blend of all natural Class I bacteria specifically chosen for their accelerated ability to metabolize hydrocarbon products such as gasoline, oil, diesel, BTEX, and phenols. Used alone they can reduce hydrocarbons by 50%. With RGF's Bio-disk Aerator System, reductions can go up to 80%. Great idea for pits, oil/water separators, ponds, bilge filters, etc.

Description	Application Area	Number per Case	Ship Wt.
RGF GT Bio-disks	Grease Traps	12	15 lbs.
RGF OWS Bio-disks	Oil Water Separators	12	15 lbs.
RGF Bio-disk Aerator System	---	---	CALL

